

DOCUMENTS ANNEXES

Annexe 1 :

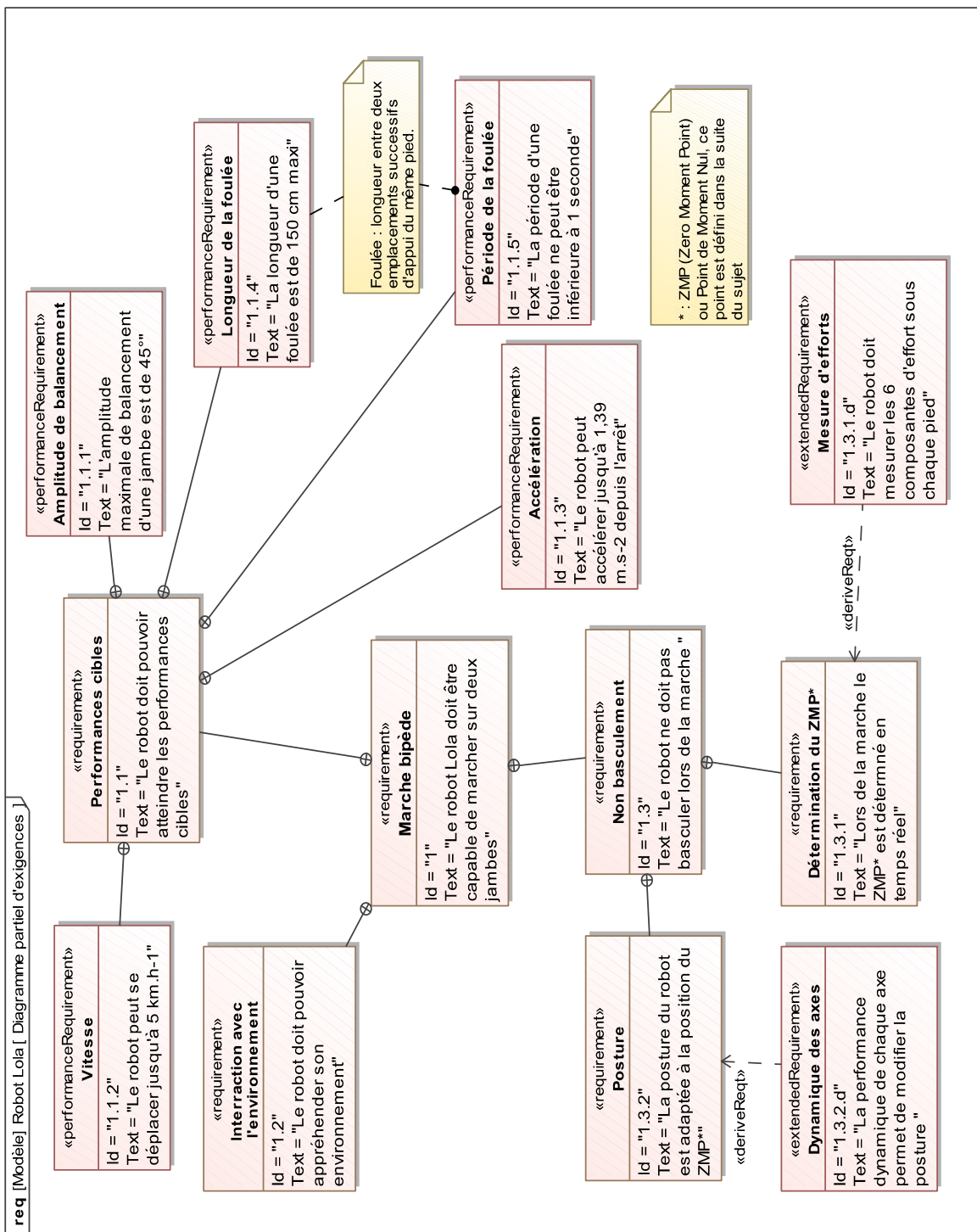

Annexe 2 : schéma-bloc de l'asservissement de position angulaire

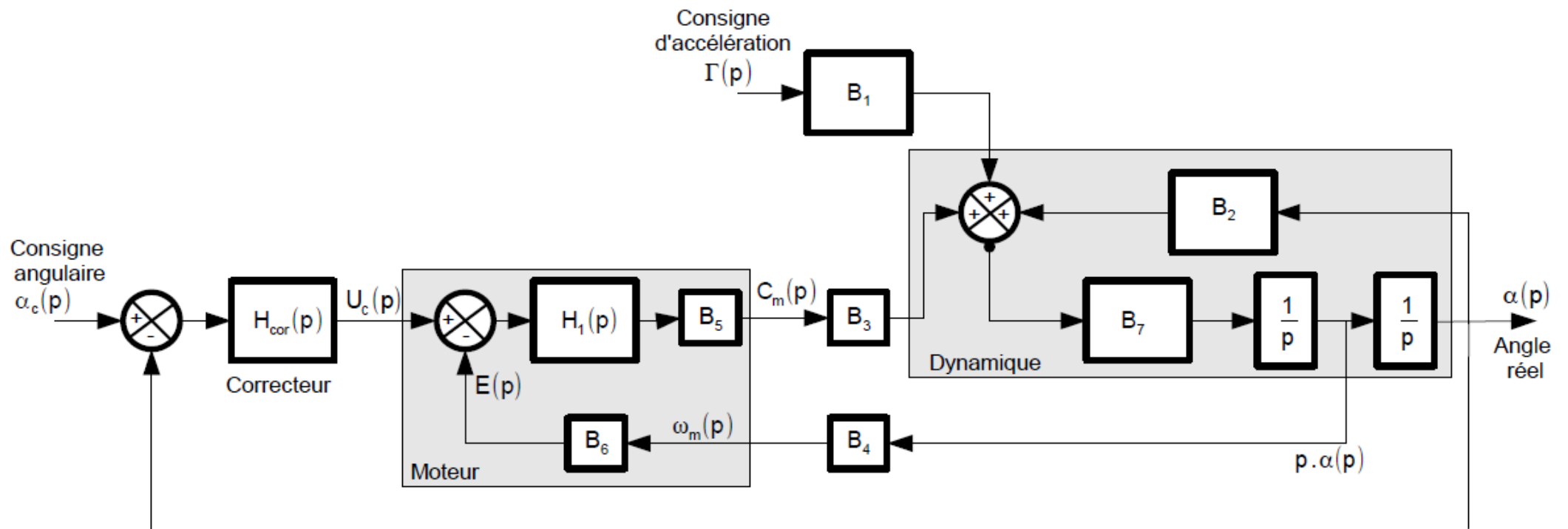

Annexe 3 : diagrammes de Bode du correcteur pour $K_p=1$

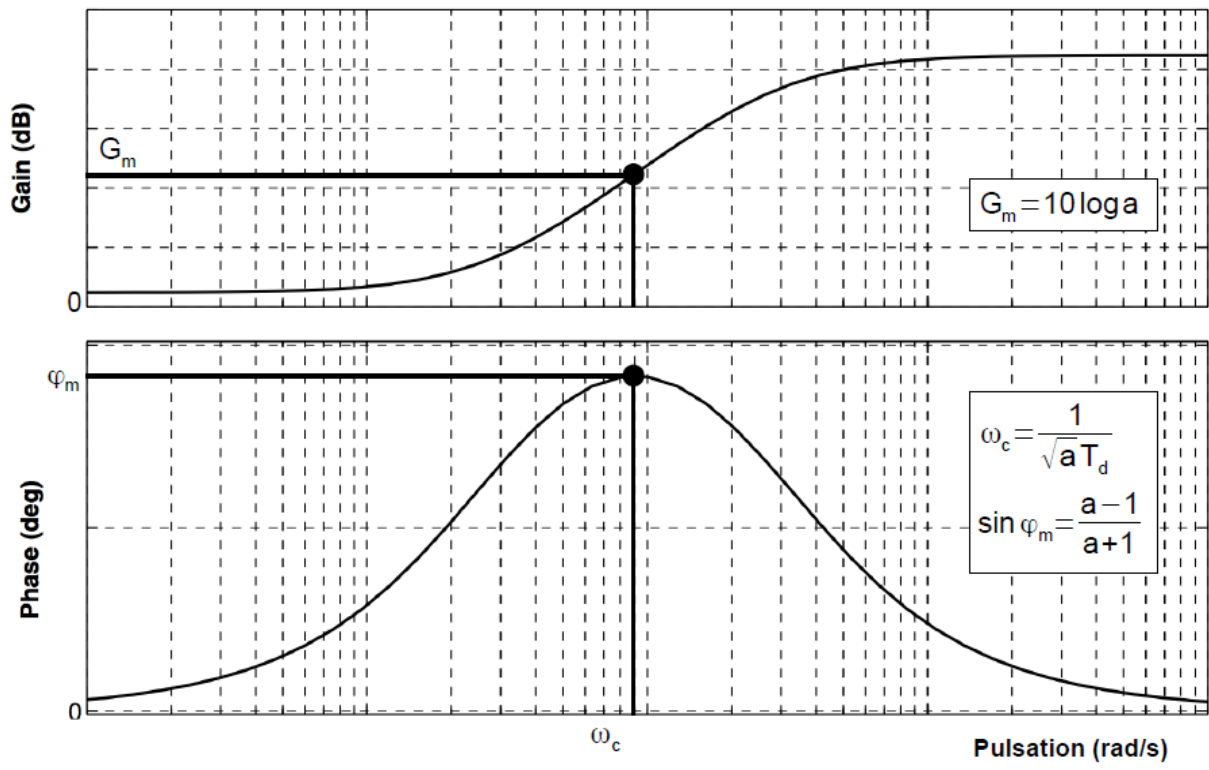

Annexe 4 : réponse temporelle

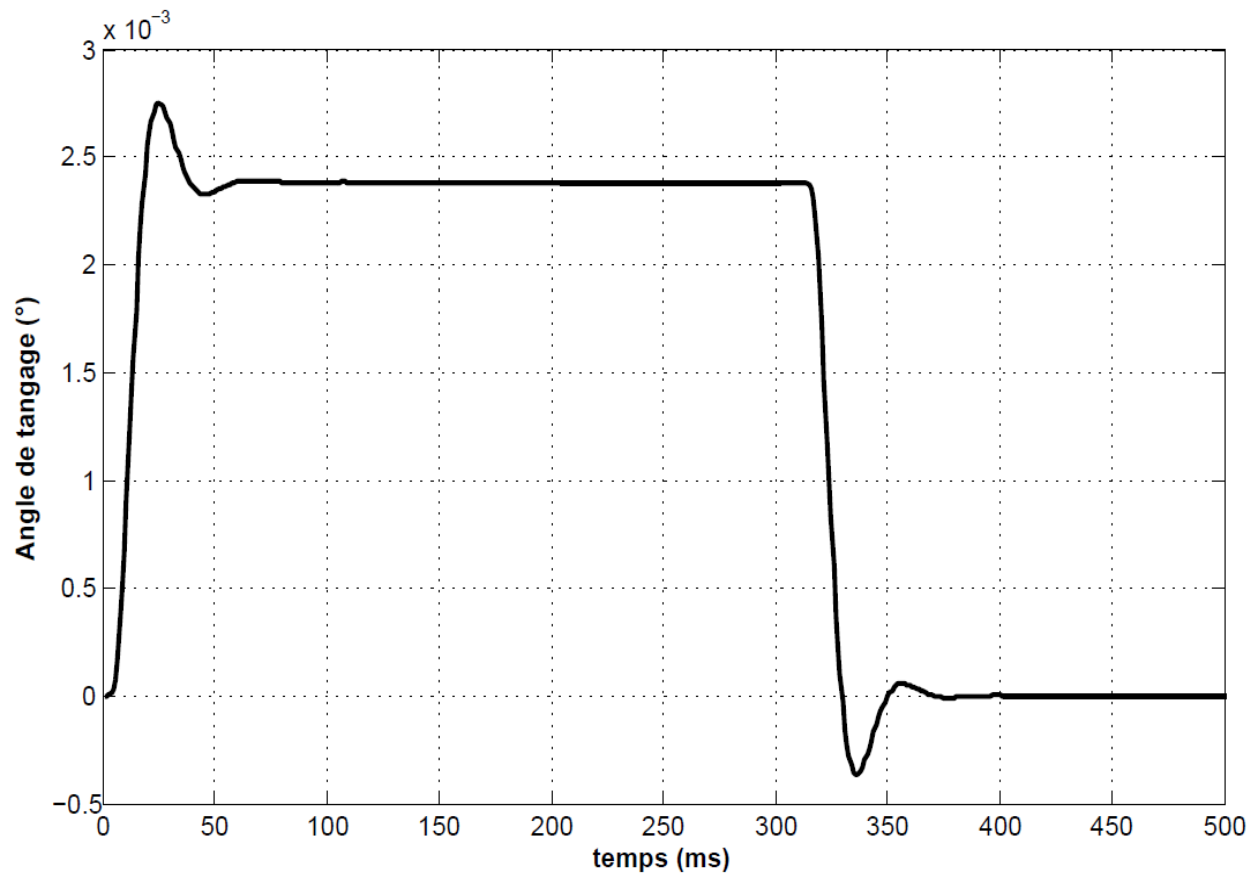

Annexe 5 : articulation en tangage de la cheville

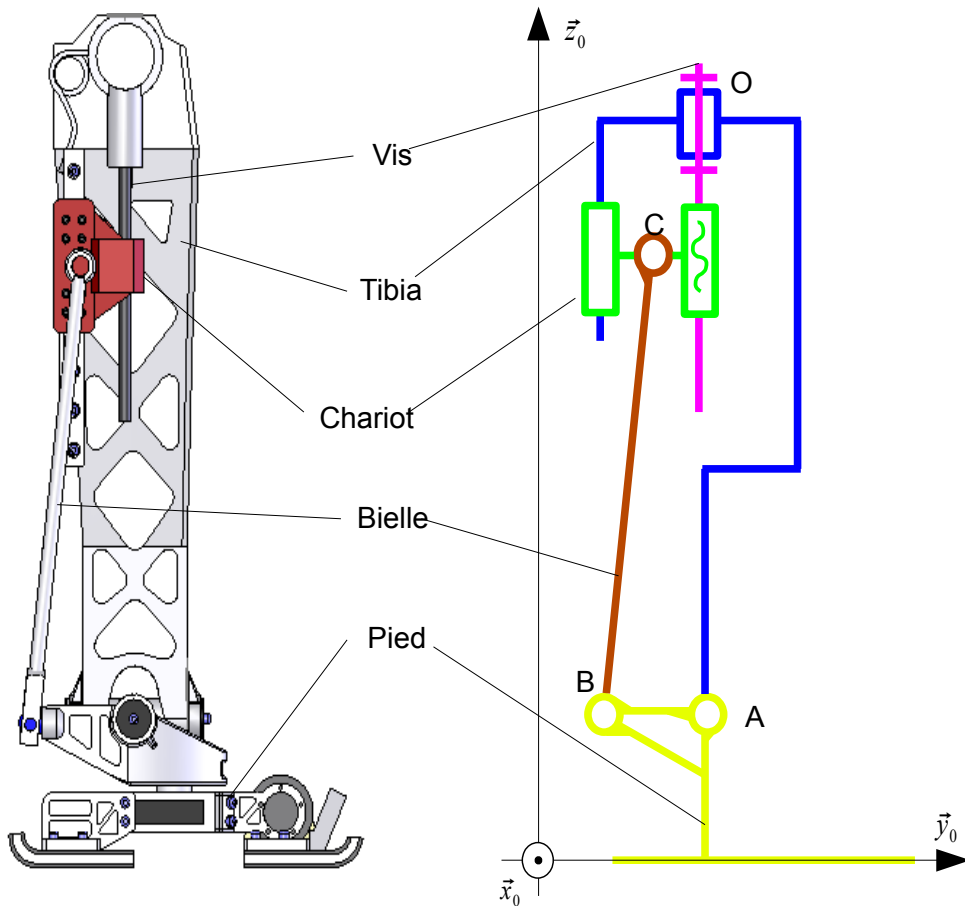
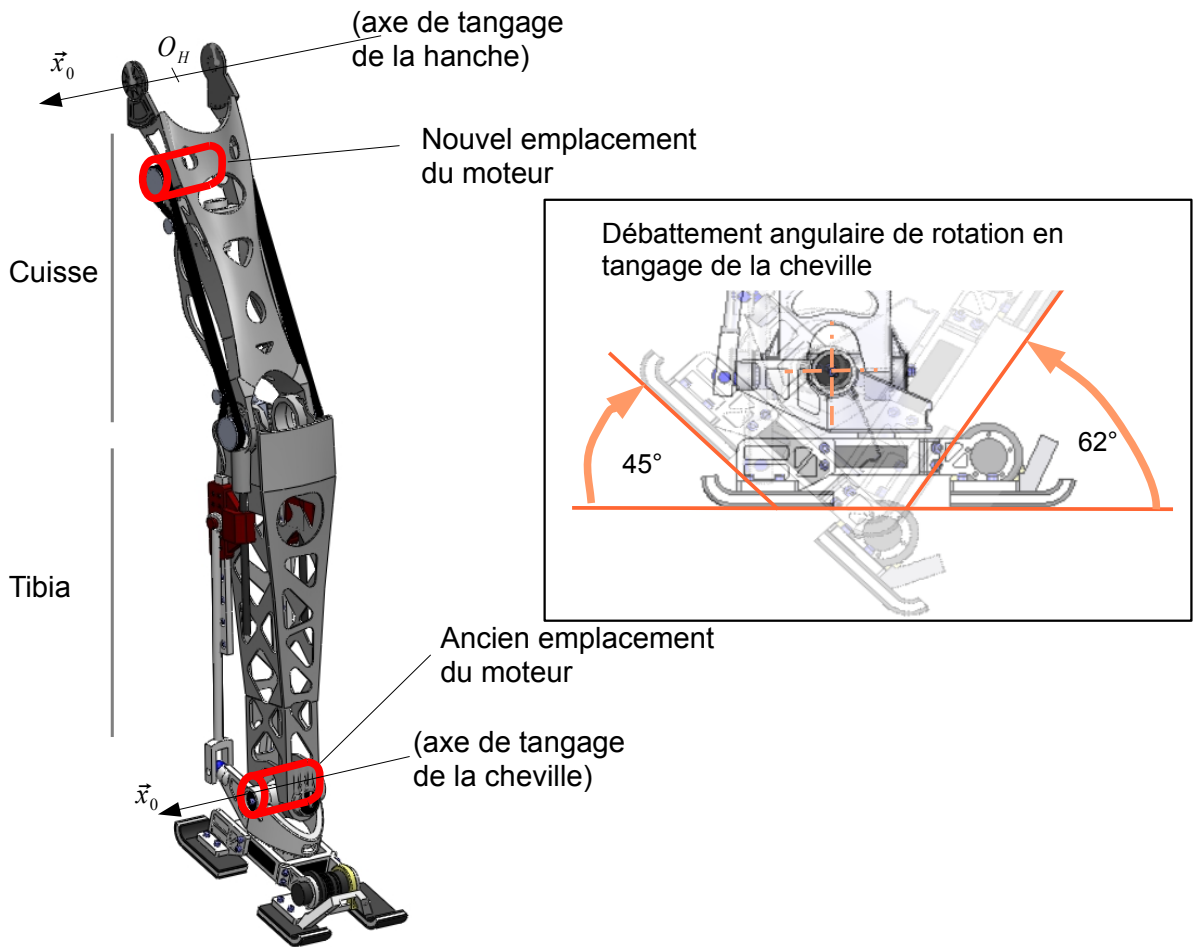

Annexe 6 : transmission de mouvement de l'articulation de la cheville

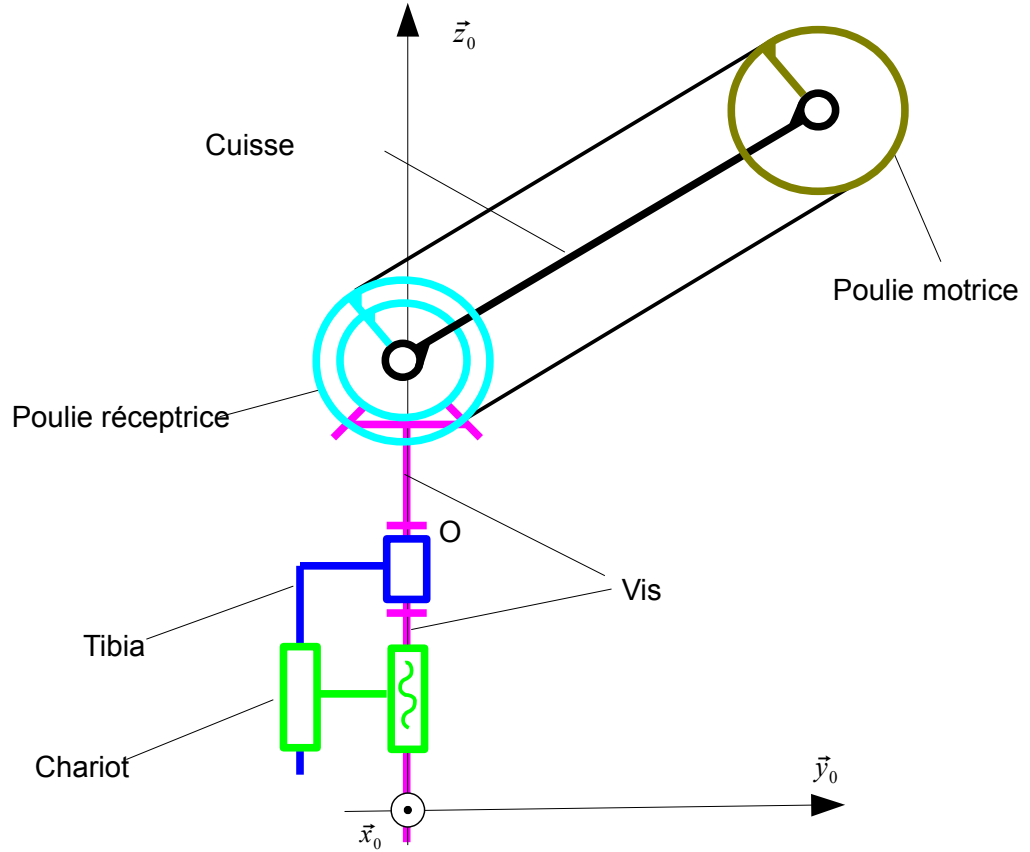

Annexe 7 : articulation de la cheville en tangage et roulis

